

OWNER'S GUIDE

ASSEMBLY • OPERATION • MAINTENANCE • PARTS

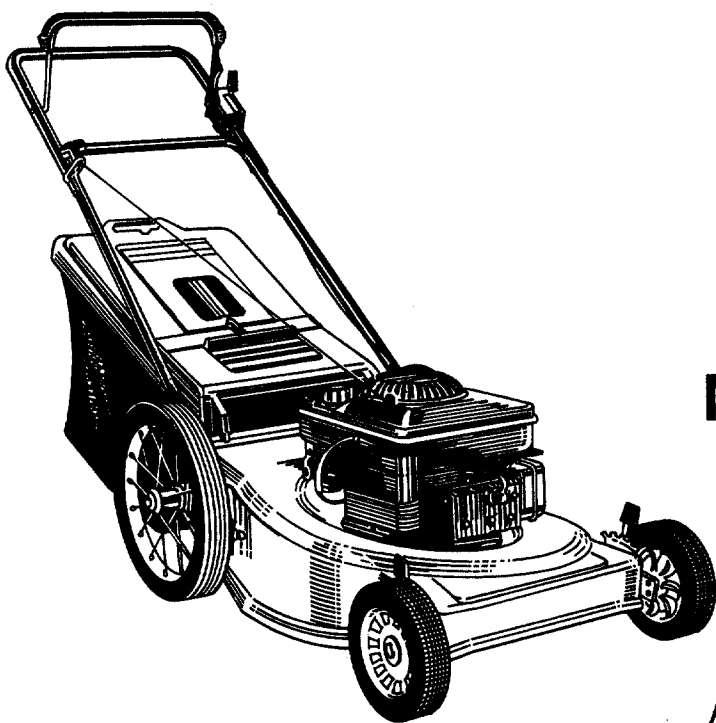

21" ROTARY MOWERS

Model Numbers
111-516R000
111-518R000

190-076-000 HARD
190-078-000 SOFT

Important: Read Safety Rules and Instructions Carefully



Made
in
AMERICA

WARNING: This unit is equipped with an internal combustion engine and should not be used on or near any unimproved forest-covered, brush-covered or grass-covered land unless the engine's exhaust system is equipped with a spark arrester meeting applicable local or state laws (if any). If a spark arrester is used, it should be maintained in effective working order by the operator.

In the State of California the above is required by law (Section 4442 of the California Public Resources Code). Other states may have similar laws. Federal laws apply on federal lands. A spark arrester for the muffler is available through your nearest engine authorized service dealer or contact the service department, P.O. Box 360900, Cleveland, Ohio 44136.

IMPORTANT

RULES FOR SAFE OPERATION



THIS SYMBOL POINTS OUT IMPORTANT SAFETY INSTRUCTIONS WHICH, IF NOT FOLLOWED, COULD ENDANGER THE PERSONAL SAFETY AND/OR PROPERTY OF YOURSELF AND OTHERS. READ AND FOLLOW ALL INSTRUCTIONS IN THIS MANUAL BEFORE ATTEMPTING TO OPERATE YOUR LAWN MOWER. FAILURE TO COMPLY WITH THESE INSTRUCTIONS MAY RESULT IN PERSONAL INJURY. WHEN YOU SEE THIS SYMBOL—



HEED ITS WARNING.



DANGER:

Your lawn mower was built to be operated according to the rules for safe operation in this manual. As with any type of power equipment, carelessness or error on the part of the operator can result in serious injury. If you violate any of these rules, you may cause serious injury to yourself or others.



TRAINING

1. Read this owner's guide carefully in its entirety before attempting to assemble or operate this machine. Be completely familiar with the controls and the proper use of this machine before operating it. Keep this manual in a safe place for future and regular reference and for ordering replacement parts.
2. Your rotary mower is a precision piece of power equipment, not a plaything. Therefore, exercise extreme caution at all times. Your unit has been designed to perform one job: to mow grass. Do not use it for any other purpose.
3. Never allow children under 14 years old to operate a power mower. Children 14 years old and over should only operate mower under close parental supervision. Only persons well acquainted with these rules of safe operation should be allowed to use your mower.
4. Keep the area of operation clear of all persons, particularly small children and pets. Stop engine when they are in the vicinity of your mower to help prevent blade contact or thrown object injury. Although the area of operation should be completely cleared of foreign objects, an object may have been overlooked and could be accidentally thrown by the mower in any direction and cause serious personal injury to the operator or any others allowed in the area.



PREPARATION

1. Thoroughly inspect the area where the equipment is to be used. Remove all stones, sticks, wire, bones and other foreign objects which could be picked up and thrown by the mower in any direction and cause serious personal injury to the operator or any others allowed in the area. Plan your mowing pattern to avoid discharge of material toward roads, sidewalks, bystanders and the like.
2. Always wear safety glasses or eye shields during operation or while performing an adjustment or repair, to protect eyes from foreign objects that may be thrown from the machine in any direction.
3. Wear sturdy, rough-soled work shoes and close-fitting slacks and shirts. Shirts and pants that cover the arms and legs and steel-toed shoes are recommended. Do not wear loose fitting clothes or jewelry. They can be caught in moving parts. Never operate a unit in bare feet, sandals, or sneakers.
4. Before working with gasoline, extinguish all cigarettes, cigars, pipes and other sources of ignition. Check the fuel level before starting the engine. Gasoline is an extremely flammable fuel. Do not fill the gasoline tank indoors, while the engine is running, or until engine has been allowed to cool for at least two minutes after running. Replace gasoline cap securely and wipe off any spilled gasoline before starting the engine as it may cause a fire or explosion.
5. Disengage the self-propelled mechanism or drive clutch on units so equipped before starting the engine.
6. The blade control handle is a safety device. Never attempt to bypass its operation. Doing so makes the safety device inoperative and may result in personal injury through contact with the rotating blade. The blade control handle must operate easily in both directions and automatically return to the disengaged position when released.
7. Never attempt to make a wheel or cutting height adjustment while the engine is running.
8. Never operate the mower in wet grass. Always be sure of your footing. A slip and fall can cause serious personal injury. Keep a firm hold on the handle and walk, never run. Mow only in daylight or in good artificial light.

9. For your safety, use the slope gauge included as part of this manual to measure slopes before operating this unit on a sloped or hilly area. If the slope is greater than 15° as shown on the slope gauge, do not operate this unit on that area or serious injury could result.



OPERATION

1. Do not change the engine governor settings or overspeed the engine. Excessive engine speeds are dangerous.
2. Do not put hands or feet near or under rotating parts. Keep clear of the discharge opening at all times as the rotating blade can cause injury.
3. Stop the blade when crossing gravel drives, walks or roads.
4. After striking a foreign object, stop the engine, remove the wire from the spark plug, and thoroughly inspect the mower for any damage. Repair the damage before restarting and operating the mower.
5. If the equipment should start to vibrate abnormally, stop the engine and check immediately for the cause. Vibration is generally a warning of trouble.
6. Shut the engine off and wait until the blade comes to a complete stop before removing the grass catcher or unclogging the chute. The cutting blade continues to rotate for a few seconds after the engine is shut off. Never place any part of the body in the blade area until you are sure the blade has stopped rotating.
7. Before cleaning, repairing or inspecting, make certain the blade and all moving parts have stopped. Disconnect the spark plug wire, and keep the wire away from the spark plug to prevent accidental starting.
8. Do not run the engine indoors.
9. Never cut grass by pulling mower toward you. Mow across the face of slopes, never up-and-down. Exercise extreme caution when changing direction on slopes. Do not mow excessively steep slopes. Always be sure of your footing. A slip and fall can cause serious personal injury.
10. Never operate mower without proper guards, plates or other safety protective devices in place.
11. Muffler and engine become hot and can cause a burn. Do not touch.
12. Do not operate this mower with the chute door open, unless the complete grass catcher or chute deflector is properly mounted on the mower.



MAINTENANCE AND STORAGE

1. Check the blade and engine mounting bolts at frequent intervals for proper tightness. Also visually inspect blade for damage (e.g. bent, cracked). Replace with blade which meets original equipment specifications.
2. Keep all nuts, bolts, and screws tight to be sure the equipment is in safe working condition.
3. Never store the mower with gasoline in the tank or gas containers inside of a building where fumes may reach an open flame or spark (e.g. gas hot water heater). Allow the engine to cool before storing in any enclosure.
4. To reduce fire hazard, keep the engine free of grass, leaves and excessive oil.
5. Check the grass catcher bag frequently for wear or deterioration. Replace a worn or damaged bag immediately. For safety protection, replace only with new bag meeting original equipment specifications.

CUT ALONG THIS LINE

USE THIS SHEET AS A GUIDE TO DETERMINE SLOPES WHERE YOU MAY NOT OPERATE SAFELY.

SLOPE GAUGE

(Keep this sheet in a safe place for future reference.)

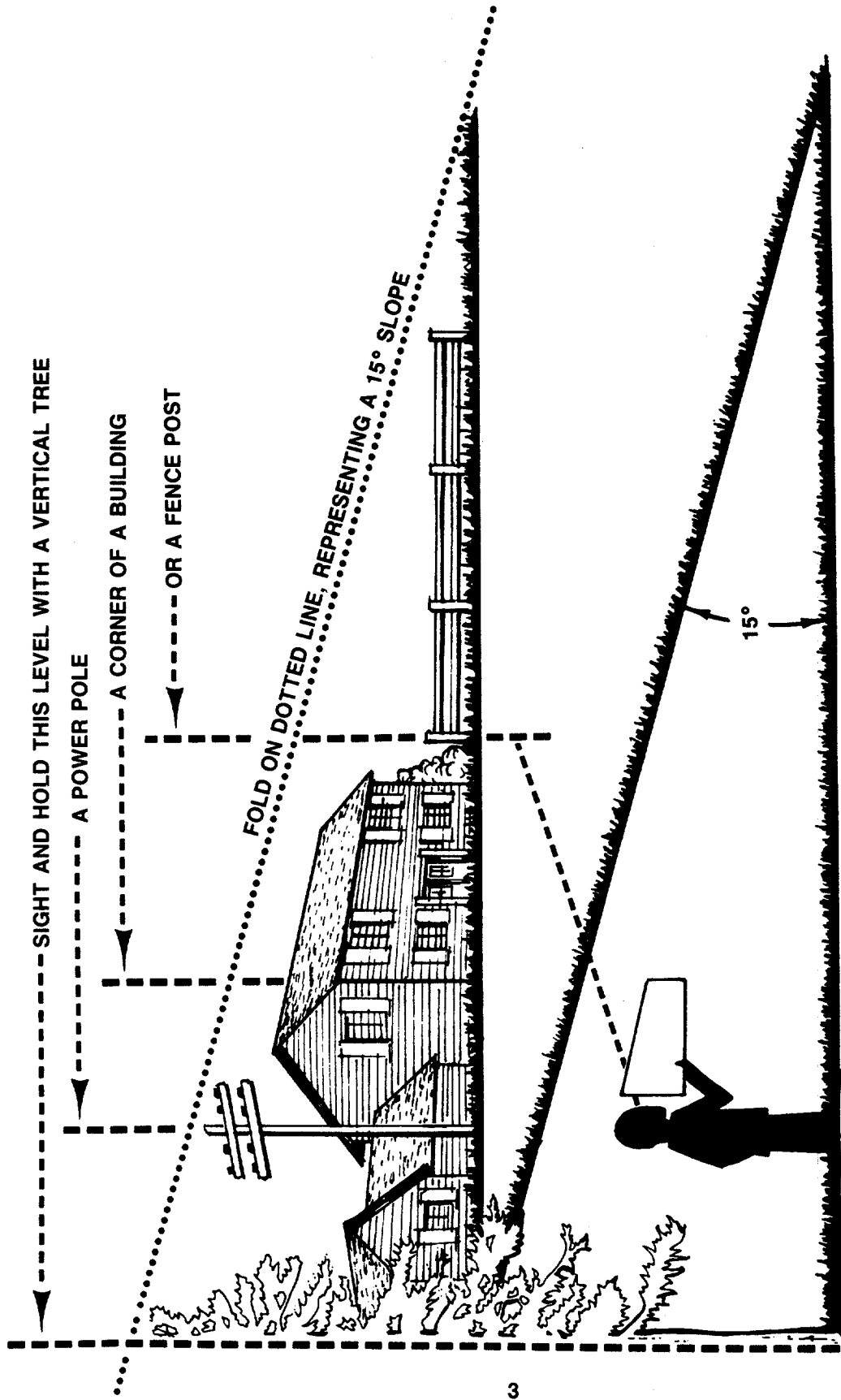

Do not mow on inclines with a slope in excess of 15 degrees (a rise of approximately 2½ feet every 10 feet). A riding mower could overturn and cause serious injury. If operating a walk-behind mower on such a slope, it is extremely difficult to maintain your footing and you could slip, resulting in serious injury.

Operate RIDING mowers up and down slopes, never across the face of slopes.
Operate WALK-BEHIND mowers across the face of slopes, never up and down slopes.

CONTENTS OF HARDWARE PACK

Remove this sheet from your owner's manual and lay the hardware on the illustration for identification purposes. After assembly, keep the Slope Gauge which is on the reverse side of this sheet for future use. (Hardware pack may contain extra items which are not used on your unit.—Part numbers are shown in parentheses.)

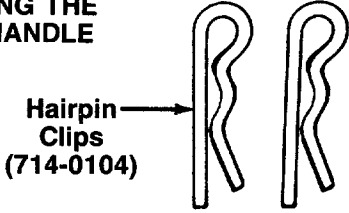
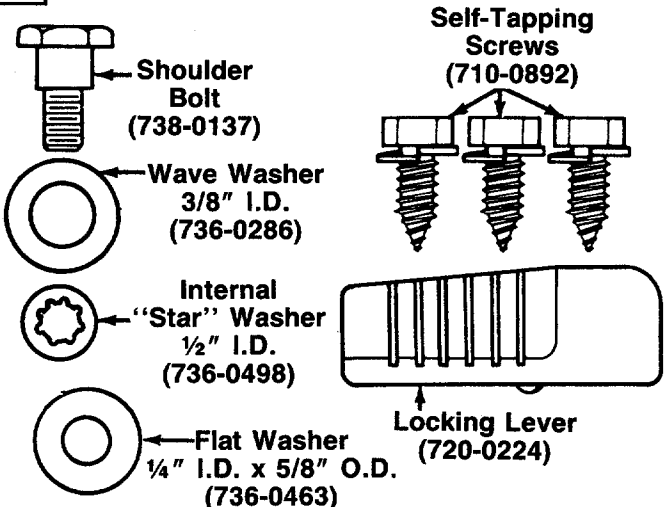
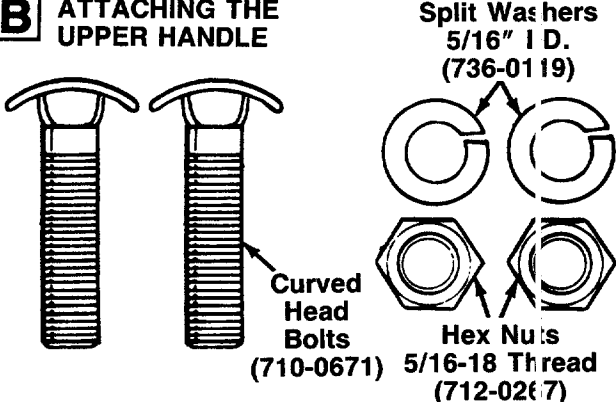
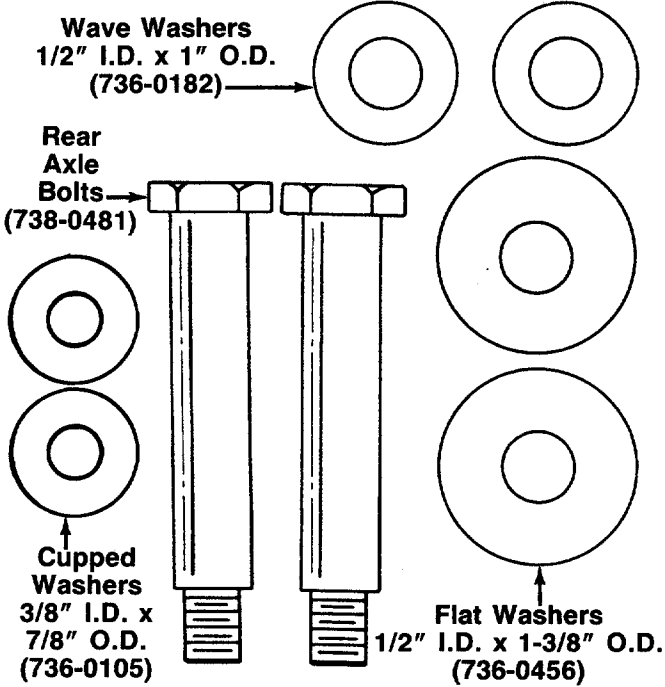
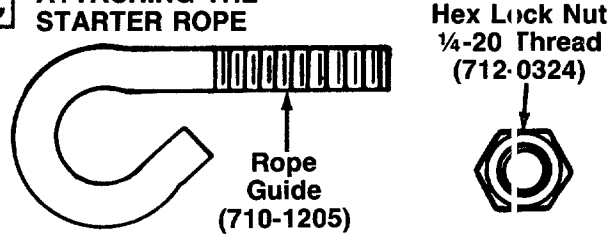
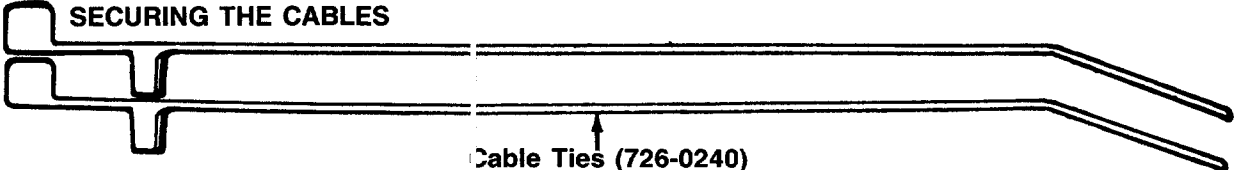
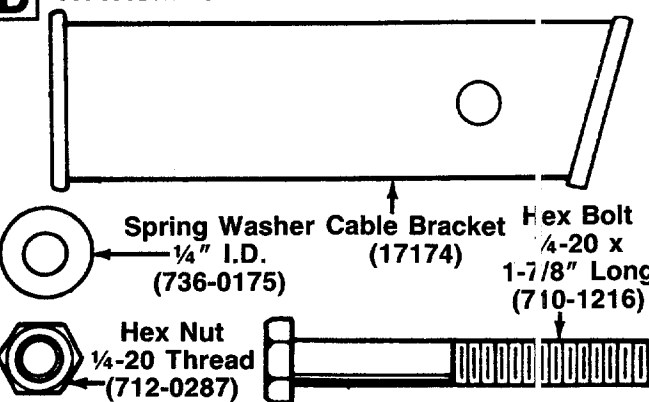
<p>A ATTACHING THE LOWER HANDLE</p>  <p>Hairpin Clips (714-0104)</p>	<p>F ASSEMBLY OF GRASS CATCHER</p>  <p>Shoulder Bolt (738-0137)</p> <p>Wave Washer 3/8" I.D. (736-0286)</p> <p>Internal "Star" Washer 1/2" I.D. (736-0498)</p> <p>Flat Washer 1/4" I.D. x 5/8" O.D. (736-0463)</p> <p>Self-Tapping Screws (710-0892)</p> <p>Locking Lever (720-0224)</p>
<p>B ATTACHING THE UPPER HANDLE</p>  <p>Curved Head Bolts (710-0671)</p> <p>Split Washers 5/16" I.D. (736-0119)</p> <p>Hex Nuts 5/16-18 Thread (712-0267)</p>	<p>G ATTACHING THE REAR WHEELS (This hardware shown approximately one-half size.)</p>  <p>Wave Washers 1/2" I.D. x 1" O.D. (736-0182)</p> <p>Rear Axle Bolts (738-0481)</p> <p>Cupped Washers 3/8" I.D. x 7/8" O.D. (736-0105)</p> <p>Flat Washers 1/2" I.D. x 1-3/8" O.D. (736-0456)</p>
<p>C ATTACHING THE STARTER ROPE</p>  <p>Rope Guide (710-1205)</p> <p>Hex Lock Nut 1/4-20 Thread (712-0324)</p>	<p>E SECURING THE CABLES</p>  <p>Cable Ties (726-0240)</p>
<p>D ATTACHING THE THROTTLE CONTROL</p>  <p>Spring Washer Cable Bracket 1/4" I.D. (736-0175)</p> <p>Hex Bolt 1/4-20 x 1-7/8" Long (710-1216)</p> <p>Hex Nut 1/4-20 Thread (712-0287)</p>	



ASSEMBLY INSTRUCTIONS

IMPORTANT: This unit is shipped **WITHOUT GASOLINE or OIL.** After assembly, service engine with gasoline and oil as instructed in the separate engine manual packed with your unit.

NOTE: Reference to right or left hand side of the mower is observed from the operating position.

Tools Required for Assembly

- (1) Pair of Pliers
- (1) 1/2" Wrench*
- (2) 7/16" Wrenches*
- (1) Adjustable Wrench*
- *Or two 6" Adjustable Wrenches

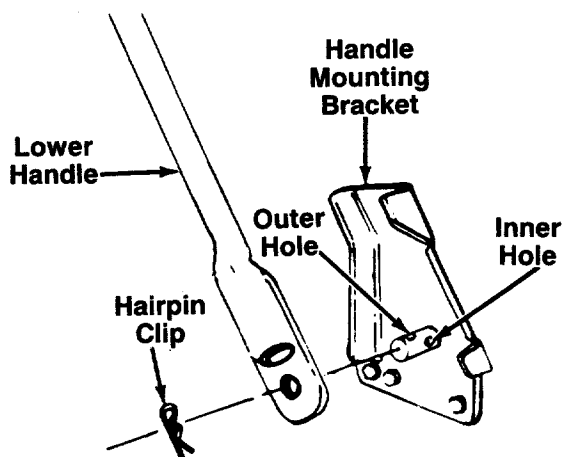

FIGURE 1.

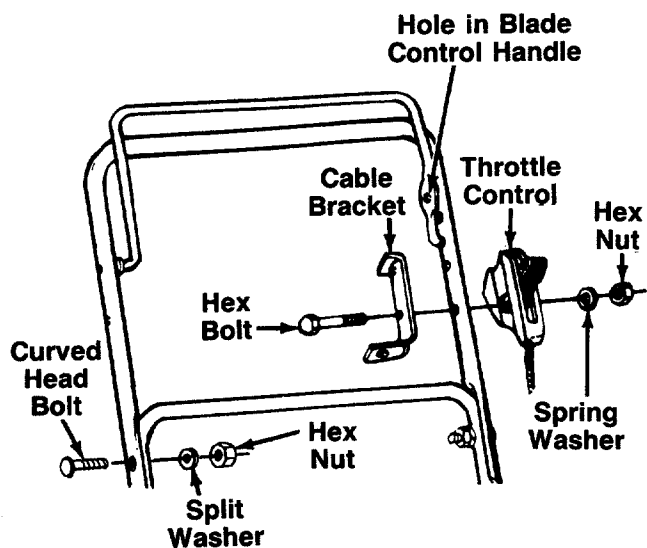

FIGURE 2.

UNPACKING

1. Remove the lawn mower from the carton by opening the top flaps and lifting the unit out. Be careful of the staples. Make certain all parts and literature have been removed from the carton before the carton is discarded.
2. Disconnect the spark plug wire and move away from the spark plug.
3. Stretch out all control cables and place on the floor. Be careful not to bend or kink the cables at any time during assembly.
4. Remove page four from this manual and lay the contents of the hardware pack on the illustration for identification.

ATTACHING THE LOWER HANDLE (Hardware A)

1. Attach the lower handle by placing the bottom holes in the lower handle over the weld pins on the handle mounting brackets on the rear of the deck. The extra hole in the upper part of lower handle must be on the **right** side of the unit.
2. Using a pair of pliers, squeeze one leg of the lower handle against the handle mounting bracket. Insert the hairpin clip into the **inner** hole on the weld pin. See figure 1. Repeat on other side.

NOTE: There are two (2) holes in the handle mounting brackets. Place the hairpin clip in the inner hole for operation. Outer hole is for storage.

ATTACHING THE UPPER HANDLE (Hardware B)

1. Place the upper handle in position over the lower handle. The hole in the side of the blade control handle (attached to the upper handle) must be on the **left** side.
2. Secure the upper handle using the curved head bolts, split washers and hex nuts as shown in figure 2. Tighten securely.

ATTACHING THE THROTTLE CONTROL (Hardware D)

The throttle control is attached to the engine. Attach the throttle control to the **left** side of upper handle as follows. See figure 2.

1. Route the throttle control cable inside the handle mounting bracket and beneath the lower handle.
2. Place cable bracket against left side of upper handle, lining up the hole in the bracket with the bottom hole in upper handle. Place 1/4" hex bolt through cable bracket and handle, from the inside to the outside.
3. Place throttle control on the hex bolt (outside of the upper handle), with the throttle lever facing upward. Secure with spring washer (cupped side against the throttle control) and hex nut.

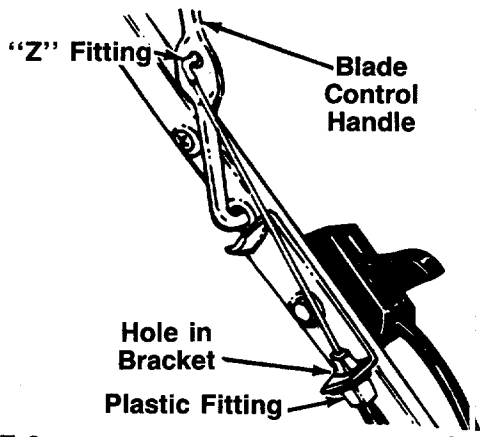

FIGURE 3.

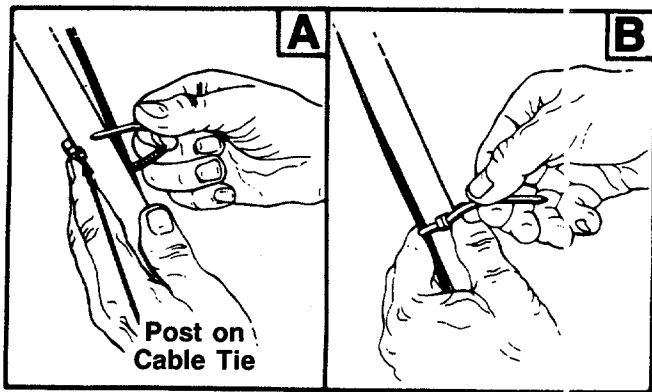

FIGURE 4.

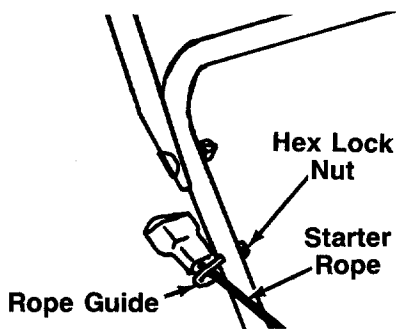

FIGURE 5.

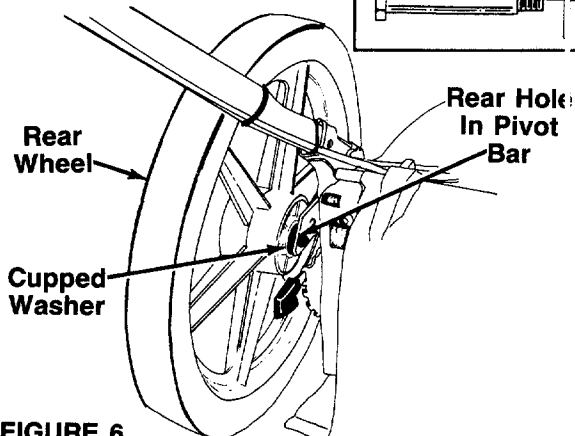
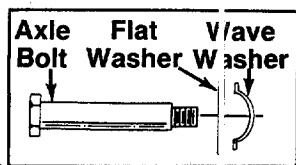

FIGURE 6.

ATTACHING THE BRAKE CABLE

1. The brake cable is attached to the engine, and has a "Z" fitting on the loose end. Route the brake cable below the lower handle. Place end of cable through the hole in the bracket as shown in figure 3.
3. Be careful not to bend or kink the cable at any time. Push the plastic fitting until it locks into the hole in the bracket.



WARNING: Brake cable must be assembled as shown for proper blade brake operation.

SECURING THE CABLES (Hardware E)

Secure all cables to the left side of the handle as follows.



WARNING: When attaching the control cables, the cables must be routed to avoid contact with all sharp edges and hot surfaces to prevent damage to the cables, which will render the controls inoperative.

1. Insert posts on cable ties into holes provided on the lower handle. The holes may be either on the inside or outside of the handles. See figure 4A.
2. Secure the cables with the cable ties. See figure 4B.
3. Trim excess ends of cable ties.

ATTACHING THE STARTER ROPE (Hardware C)

1. The starter rope is inside the top of the engine. Additional rope may be wound around the starter handle. If so, unwind the rope from the handle.
2. With the spark plug wire disconnected and grounded, depress the blade control handle and pull the rope out of the engine.
3. Place the rope guide around the starter rope, so the rope guide is positioned as shown (bends downward slightly). Insert the rope guide through the right side of the lower handle, and secure with hex lock nut. See figure 5.

ATTACHING THE REAR WHEELS (Hardware G)

Assemble the rear wheels as follows. See figure 6.

1. Move the wheel height adjusters so the deck is in the lowest cutting position.
2. Lift the rear of the unit up and block securely.
3. Place one large flat washer on axle bolt, then the wave washer (cupped side against the flat washer as shown in figure 6, inset).
4. Insert axle bolt through one rear wheel. Place cupped washer on axle bolt (crowned side of washer goes against the wheel).

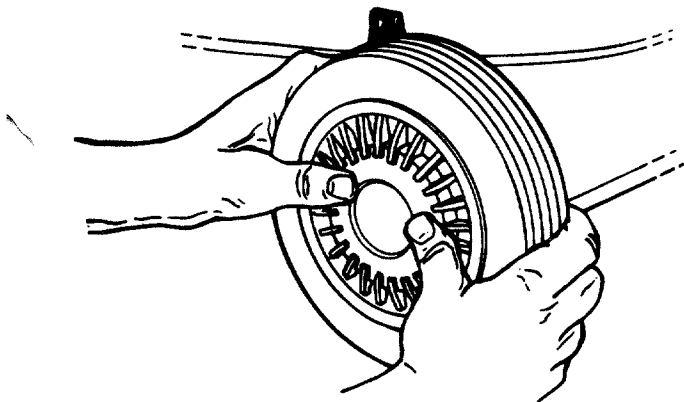

FIGURE 7.—Optional Hub Caps

5. Thread axle bolt into rear hole of pivot bar. Tighten securely.
6. Assemble other rear wheel in the same manner.

INSTALLATION OF HUB CAPS (Optional)

1. If your mower is equipped with hub caps which have four tabs, line up the tabs on the hub caps with the holes in the wheels. Push to lock in position.
2. If your mower is equipped with 2" wide tires, place hub caps in position against the inner hub of the wheel. Press firmly around the center portion of hub cap in a circular motion, similar to installing a lid on a round, plastic container. See figure 7. The hub caps are flexible and will snap over the 3½" diameter wheel hubs.

NOTE: It may be helpful to place the hub caps in hot tap water for several minutes to make them pliable before installing, especially if the temperature is less than 60° F.

FINAL ASSEMBLY OF MOWER

Make certain all nuts and bolts are tightened securely.

ASSEMBLY OF GRASS CATCHER (Hardware F)

NOTE: Make certain the grass bag is turned right side out before assembling (warning label will be on the outside).

1. There are three holes in the rear frame. With the holes on the upper side as shown in figure 8A, insert one end of the rear frame into the cloth channel on the edge of the grass catcher bag. Feed all the material on one side of the frame, then work it around the frame. See figure 8B.

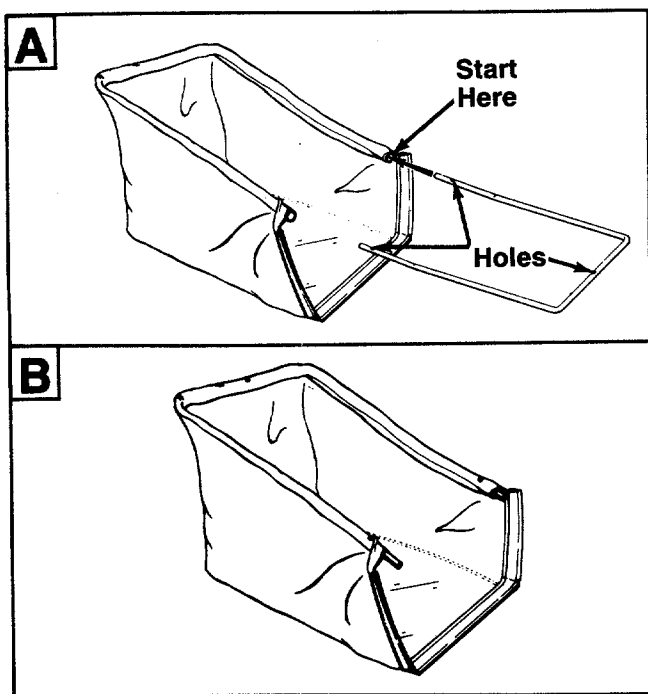

FIGURE 8.

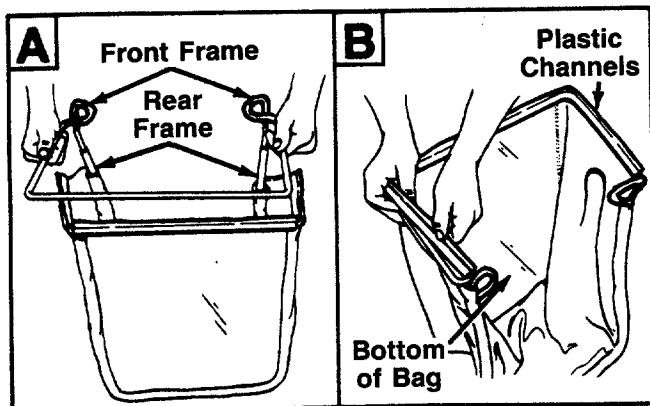

FIGURE 9.

2. Slide the ends of the front frame assembly into the ends of the rear frame as shown in figure 9A.
3. Secure front of bag to front frame by slipping plastic channels on sides and bottom of bag over frame. See figure 9B.

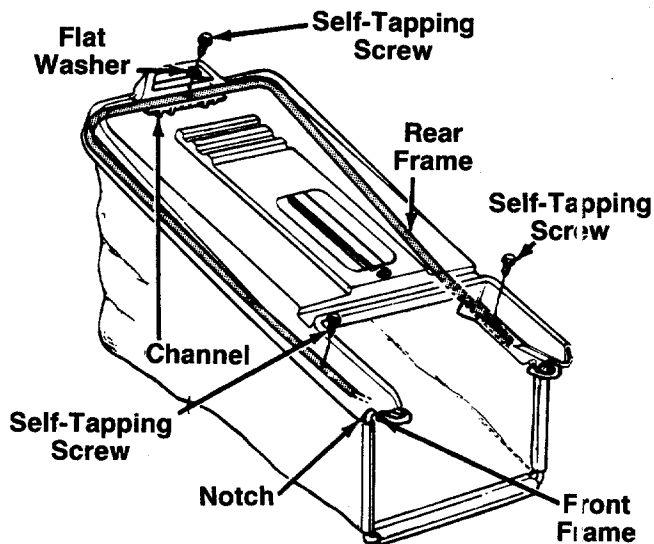

FIGURE 10.

4. Attach the hardtop cover to the grass catcher as follows. See figure 10.

- a. Place the cover in position on top of the grass catcher. Press the rear frame into the channel on the rear of the cover (beneath the rear handle).
- b. Slide the notches on the sides of the cover over the front catcher frame.
- c. Attach rear of cover to frame using the flat washer and one self-tapping screw as shown in figure 10. Attach the sides of the cover to frame with the other two self-tapping screws.

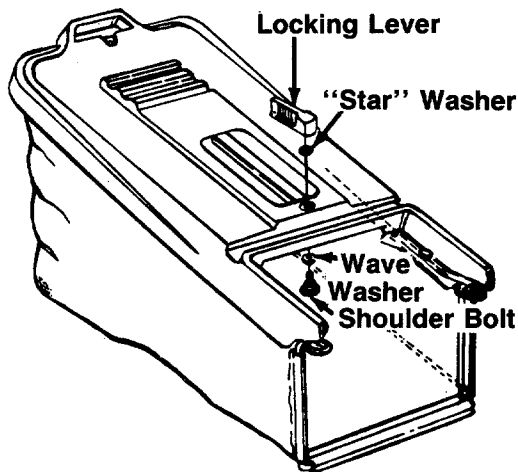

FIGURE 11.

5. Assemble the locking lever as follows:

- a. Place wave washer on shoulder bolt (crowned side of washer goes against the head of bolt).
- b. Insert shoulder bolt up through hole in hardtop cover as shown in figure 11. Place "star" washer over shoulder bolt.
- c. Thread shoulder bolt into the grass catcher locking lever, using a 9/16" socket wrench. Do not overtighten. Locking lever must be able to pivot.

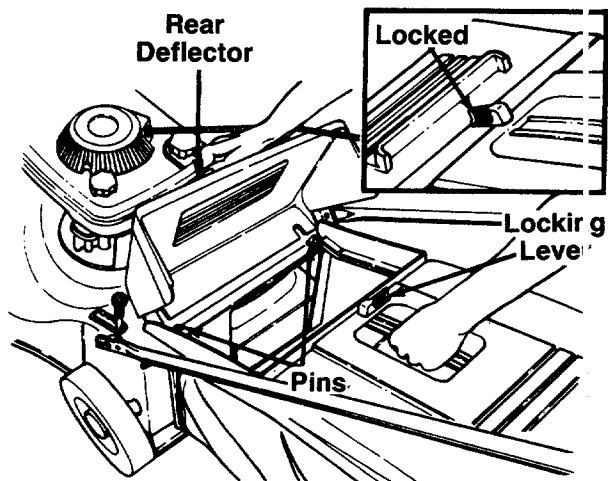

FIGURE 12.

ATTACHING BAG TO MOWER

Lift the rear deflector on the mower. Place the loops on the grass catcher frame over the pins on the back of the mower. See figure 12. Release the rear deflector. Turn the locking lever to the locked position to secure the rear deflector. See figure 12, inset.

To remove the grass catcher, turn the locking lever to the unlocked position and lift the rear deflector on the mower. Lift the grass catcher up, over the pins on the back of the mower. Release the deflector.

CONTROLS

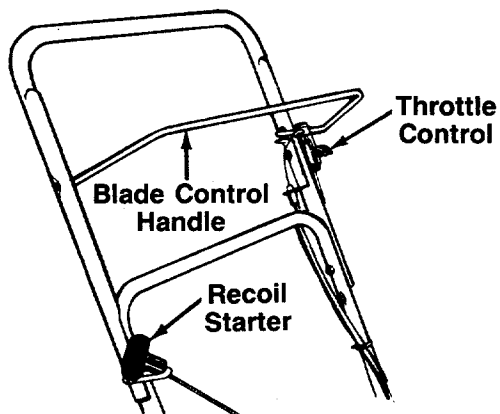

FIGURE 13.

BLADE CONTROL HANDLE



WARNING: This control mechanism is a safety device. Never attempt to bypass its operations.

The blade control handle is located on the upper handle of the mower. See figure 13. The blade control handle must be depressed in order to operate the unit. Release the blade control handle to stop the engine and blade.



WARNING: The blade will be rotating whenever the engine is running.

THROTTLE CONTROL

The throttle control is located on the side of the upper handle. It is used to regulate the engine speed.



WARNING: The throttle control cannot be used to stop the engine.

RECOIL STARTER

The recoil starter handle is attached to the handle. See figure 13. Stand behind the unit in the operating position to start the unit.

OPERATION



FIGURE 14.

Keep hands and feet away from the chute area on cutting deck. See figure 14.

The operation of any lawn mower can result in foreign objects being thrown into the eyes, which can result in severe eye damage. Always wear safety glasses or eye shields. We recommend wide vision safety mask for over spectacles or standard safety glasses.



NOTE: For shipping purposes your mower is set with the wheels in a low cutting height position. For best results raise the cutting position until it is determined which height is best for your lawn. See cutting height adjustment section.

GAS AND OIL FILL-UP

Service the engine with gasoline and oil as instructed in the separate engine manual packed with your mower. Read instructions carefully.



WARNING: Never fill fuel tank indoors, with engine running or until the engine has been allowed to cool for at least two minutes after running.

TO START ENGINE AND ENGAGE BLADE

1. Attach spark plug wire to spark plug. If unit is equipped with a rubber boot over the end of the spark plug wire, make certain the metal loop on the end of the spark plug wire (inside the rubber boot) is fastened securely over the metal tip on the spark plug. See figure 15.

Metal Loop on Spark Plug Wire

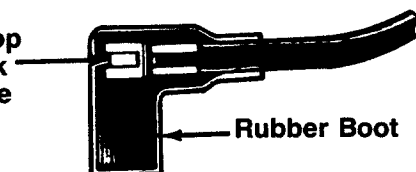

FIGURE 15.

2. Open fuel shut-off valve (if so equipped). Refer to separate engine manual.
3. Move throttle control lever all the way forward.
4. **Tecumseh engines only:** Prime engine as instructed in the separate engine manual packed with your unit.
5. Standing behind the unit, depress the blade control handle and hold it against the upper handle as shown. See figure 16.
6. Grasp the recoil starter handle and pull back rapidly, extending rope fully. Return it slowly to the rope guide.
7. After engine starts, move throttle control to desired engine speed.

NOTE: If any problems are encountered, refer to the *Trouble Shooting Guide* on page 16.

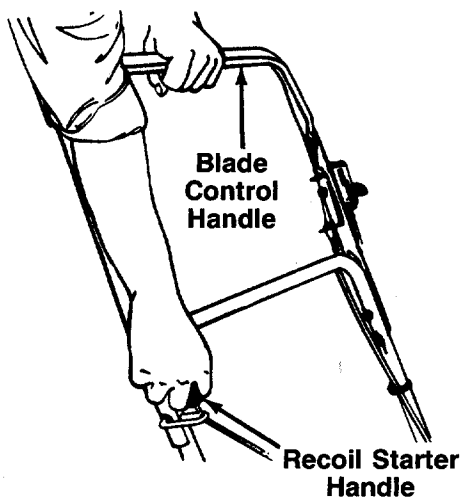

FIGURE 16.

TO STOP ENGINE AND BLADE

1. Move throttle control lever to SLOW position.
2. Release the blade control handle to stop the engine and blade.



WARNING: The blade continues to rotate for a few seconds after the engine is shut off.

3. Disconnect the spark plug wire and ground it against the engine to prevent accidental starting while equipment is unattended.

USING YOUR ROTARY MOWER



WARNING: Never operate your unit without either the rear deflector or entire grass catcher assembly in place.

Be sure that lawn is clear of stones, sticks, wire, or other objects which could damage lawn mower or engine.

Such objects could be accidentally thrown by the mower in any direction and cause serious personal injury to the operator and others.

For the best results, do not cut wet grass because it tends to stick to the underside of the mower, preventing proper discharge of grass clippings, and could cause you to slip and fall. New grass, thick grass or wet grass may require a narrower cut. Blade speed should be adjusted to the condition of the lawn.

For best results, cut off one-third or less of the total length of the grass. Lawn should be cut in the fall as long as there is growth.

This mower is designed to be operated at full throttle to give you the best cut and do the most effective job of bagging the cut grass.



WARNING: If you strike a foreign object, stop the engine. Remove wire from spark plug, thoroughly inspect the mower for any damage, and repair the damage before restarting and operating the mower. Extensive vibration of the mower during operation is an indication of damage. The unit should be promptly inspected and repaired.

ADJUSTMENTS



WARNING: Do not at any time make any adjustment to lawn mower without first stopping engine and disconnecting spark plug wire.

CUTTING HEIGHT ADJUSTMENT

An adjusting plate and thumb lever at each wheel position provides cutting height adjustment. Each adjusting plate has nine height positions. Height of cut will be changed when the thumb lever is moved from one hole to another. Simply depress the lever towards wheel and move wheel and lever assembly to desired position. All wheels must be placed in the same relative position. See figure 17.

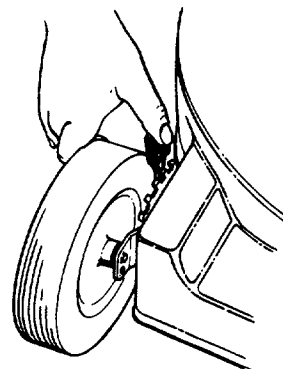

FIGURE 17.

THROTTLE CONTROL ADJUSTMENT

If the throttle control requires adjustment or if it has been replaced, adjust as follows.

1. Remove the screw shown in figure 18. Remove the cable clamp from the cable.
2. Push the throttle control lever on the handle all the way forward to CHOKE position. Make certain the throttle control lever remains in this position.
3. Push the control lever on the engine as far toward the rear of the engine as it will go. Secure the cable in this position with the cable clamp and screw.

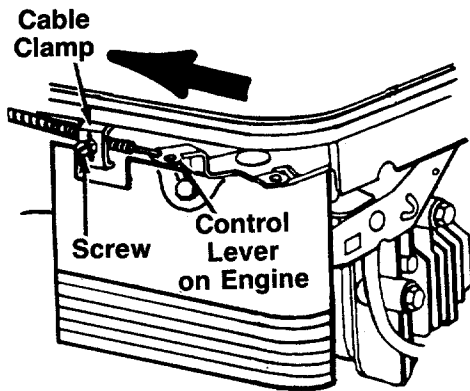

FIGURE 18.

CARBURETOR ADJUSTMENTS

WARNING: If any adjustments are made to the engine while the engine is running (e.g. carburetor), keep clear of all moving parts. Be careful of heated surfaces and muffler.

Minor carburetor adjustments may be required to compensate for differences in fuel, temperature, altitude and load. To adjust carburetor, refer to the separate engine manual packed with your mower.

NOTE: A dirty air cleaner will cause an engine to run rough. Be certain air cleaner is clean and attached to the carburetor before adjusting carburetor. Refer to the separate engine manual.

LUBRICATION

WARNING: Always stop engine and disconnect spark plug wire before cleaning, lubricating or doing any kind of work on lawn mower.

Blade Control—Lubricate the pivot points on the blade control handle and the brake cable at least once a season with light oil. See figure 19. The blade control must operate freely in both directions.

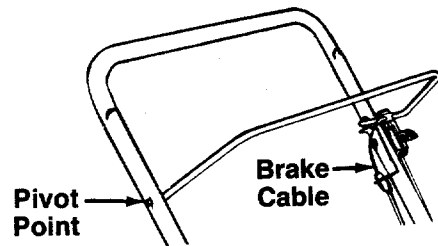

FIGURE 19.

Discharge Chute Deflector—The torsion spring and pivot point should be lubricated periodically with light oil to prevent any rust or binding. Deflector must work freely.

Wheels—Mower may be provided with ball bearing wheels. Lubricate at least once a season with light oil. Also, if the wheels are removed for any reason, lubricate the surface of the axle bolt and the inner surface of the wheel with light oil. A 4 oz. plastic bottle of light oil lubricant is available. Order part number 737-0170. Engine oil may also be used.

Engine—Follow engine manual for lubrication instructions.

Throttle—Periodically lubricate throttle control lever and throttle wire assembly with a few drops of light oil for ease of operation.

MAINTENANCE

WARNING: Be sure to disconnect and ground the spark plug wire before performing any repairs or maintenance.

NOTE: When tipping the unit, empty the fuel tank and keep engine spark plug or muffler side up.

TROUBLE SHOOTING

Refer to page 16 of this manual for trouble shooting information.

CUTTING BLADE

When removing the cutting blade for sharpening or replacement, protect hands by using heavy gloves or a rag to grasp the cutting blade. Remove the bolt and bell washer which hold the blade and adapter to the engine crankshaft. Remove the blade and adapter from the crankshaft.

If the blade or blade adapter needs replacing, remove the two small bolts, lock washers and nuts which hold the blade to the adapter.

WARNING: Periodically inspect the blade adapter for cracks, especially if you strike a foreign object. Replace when necessary.

When sharpening the blade, follow the original angle of grind as a guide. It is **extremely important** that each cutting edge receives an equal amount of grinding to prevent an unbalanced blade. An unbalanced blade will cause excessive vibration when rotating at high speeds, may cause damage to the mower and could break, causing personal injury.

It is recommended that the blade always be removed from the adapter for the best test of balance.

The blade can be tested by balancing it on a round shaft screwdriver. Remove metal from the heavy side until it balances evenly.

Before reassembling the blade and the blade adapter to the unit, lubricate the engine crankshaft and the inner surface of the blade adapter with light oil. Lubricating the bolt holes, bolts and inner surface of the nuts with light oil is also recommended. A 4 oz. plastic bottle of light oil lubricant is available. Order part number 737-0170. Engine oil may also be used.

When replacing the blade, be sure to install the blade with the side of the blade marked "Bottom" (or with part number) facing the ground when the mower is in the operating position.

Blade Mounting Torque

Center Bolt and Blade Adapter Bolts:
375 in. lb. min., 450 in. lb. max.

To insure safe operation of your unit, **all** nuts and bolts must be checked periodically for correct tightness.

DECK

The underside of the mower deck should be cleaned after each use to prevent a buildup of grass clippings, leaves, dirt or other matter. If this debris is allowed to accumulate, it will invite rust and corrosion, and may cause an uneven discharge of grass clippings at the next cutting.

The deck may be cleaned by tilting the mower and scraping clean with a suitable tool (make certain the spark plug wire is disconnected).

ENGINE

Refer to the separate engine manual for engine maintenance instructions.

Maintain **engine oil** as instructed in the separate engine manual packed with your unit. Read and follow instructions carefully.

Service **air cleaner** every 25 hours under normal conditions. Clean every few hours under extremely dusty conditions. Poor engine performance and flooding usually indicates that the air cleaner should be serviced. To service the air cleaner, refer to the separate engine manual packed with your unit.

The **spark plug** should be cleaned and the gap reset once a season. Spark plug replacement is recommended at the start of each mowing season; check engine manual for correct plug type and gap specifications.

Clean the engine regularly with a cloth or brush. Keep the cooling system (blower housing area) clean to permit proper air circulation which is essential to engine performance and life. Be certain to remove all grass, dirt and combustible debris from muffler area.

OFF-SEASON STORAGE

The following steps should be taken to prepare lawn mower for storage.

1. Clean and lubricate mower thoroughly as described in the lubrication instructions.
2. Refer to engine manual for correct engine storage instructions.
3. Coat mower's cutting blade with chassis grease to prevent rusting.
4. Store mower in a dry, clean area.

NOTE: *When storing any type of power equipment in an unventilated or metal storage shed, care should be taken to rust-proof the equipment. Using a light oil or silicone, coat the equipment, especially cables and all moving parts.*

HANDLE STORAGE

The handle may be placed in an upright position for storage. Move hairpin clips to outer hole on weld pins. See figure 1. Press outward on the bottom of the lower handle and push forward. The handle will lock in this position.

To place the handle in the operating position, remove the starter rope from the rope guide. Grasp the lower handle at the bottom, press outward slightly and tip the handle backward. Place the hairpin clips in the inner holes. With the spark plug wire disconnected and grounded, depress the blade control handle and pull the starter rope out from the engine. Slip the starter rope into the rope guide.

*For faster service obtain standard nuts, bolts and washers locally. If these items cannot be obtained locally, order by part number and size as shown on parts list.

CODE: N notates a **new part** (not previously existing). A three digit number is the **color code**. Specify color code as shown below if color or finish is important when ordering parts. [i.e., -638 for Red Finish].

NOTE: The engine is not under warranty by the mower manufacturer... If repairs or service is needed on the engine, please contact your nearest authorized engine service outlet. Check the "Yellow Pages" of your telephone book under "Engines—Gasoline."

**Find It Fast
in The
Yellow Pages**

Color Codes

456—Radiant Tangerine	629—Silver Flake
460—Green Flake	630—Metallic Blue
483—Charcoal Gray	637—Black
498—Yellow	638—Red
499—Beige	640—Green
621—Brilliant Fire Mist	646—CM Blue

Models 516R and 518R

OPTIONAL HUB CAPS

Description	Part No.
Gray (5-1/2" Dia.)	731-0981A
Beige (5-1/2" Dia.)	731-0982A
Gray (3-1/2" Dia.)	720-0249
Black (1-1/2" Dia.)	720-0251
Red (1-3/8" Dia.)	731-0342
Black (1-3/8" Dia.)	731-0268

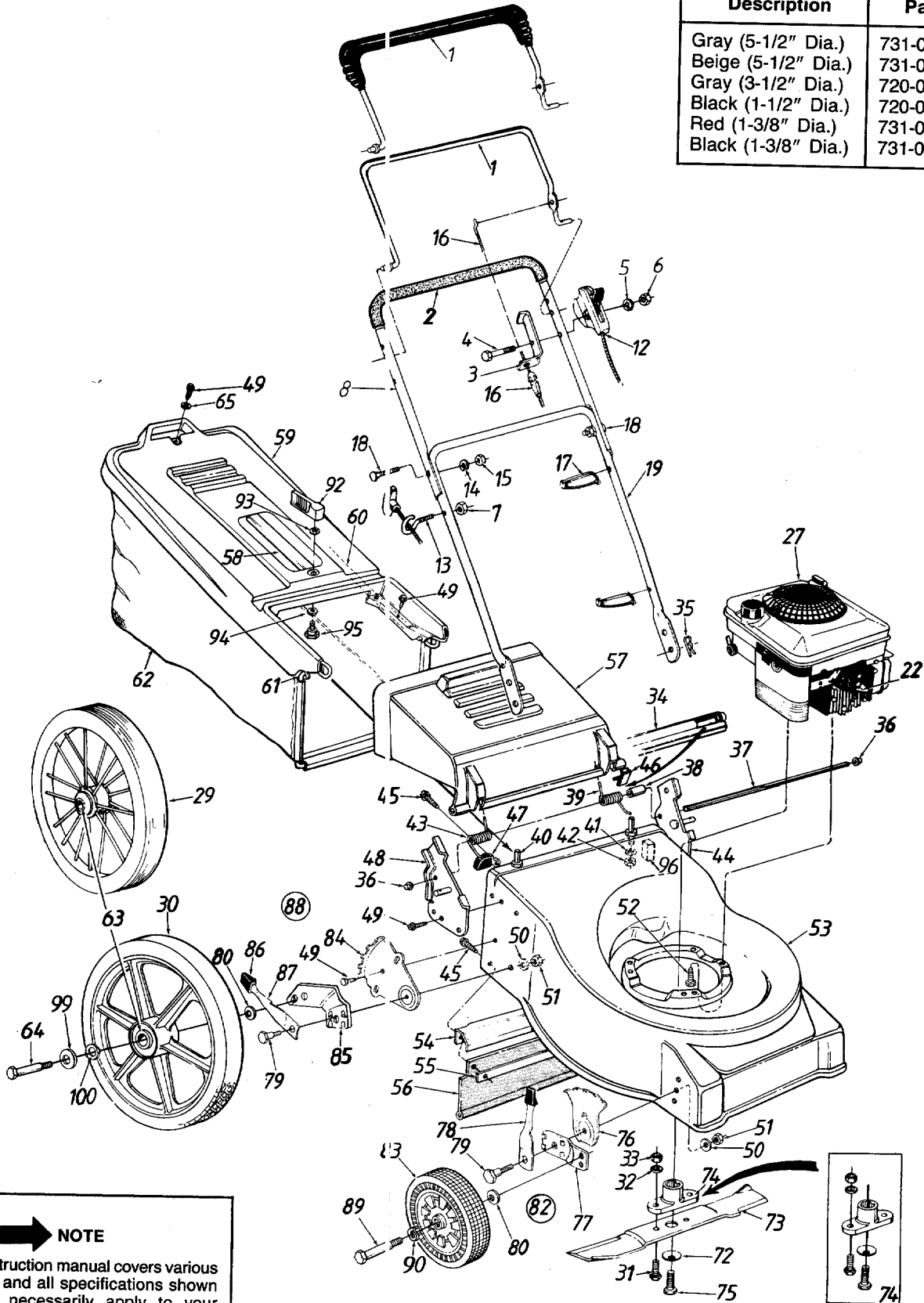

NOTE







This instruction manual covers various models and all specifications shown do not necessarily apply to your model. Specifications subject to change without notice or obligation.

PARTS LIST FOR MODELS 516R AND 518R ROTARY MOWERS

REF. NO.	PART NO.	CODE	DESCRIPTION	REF. NO.	PART NO.	CODE	DESCRIPTION
1	747-0748		Control Handle Ass'y. (Std.)	52	710-0654A		Hex L-Wash. Hd. Scr. 3/8-16 x 1" Lg.
	731-1135		Control Handle Ass'y. (Deluxe)			638	21" Deck Ass'y.
2	720-0226		Foam Grip (Optional)	53	16998		Chute Baffle
3	17174		Cable Brkt.	54	17014		Retaining Strip 14.25" Lg.
4	710-1216		Hex Bolt 1/4-20 x 1.875" Lg.	55	17003		Rear Flap 17.30" Lg.
5	736-0175		Spr. Wash. 1/4" I.D.	56	731-0669		Rear Chute Deflector
6	712-0287		Hex Nut 1/4-20 Thd.	57	731-0859		Hardtop Handle
7	712-0324		Hex L-Nut 1/4-20 Thd.	58	731-0856		Hardtop Bag Cover
8	749-0438B		Upper Handle	59	731-0857A		Rear Catcher Frame
12	746-0821		Throttle Control Ass'y. Comp.—56.6"	60	749-0736A	N	Front Catcher Frame
		N		61	764-0411		Grass Bag
13	710-1205		Rope Guide	62	764-0252		Bearing (2 Per Wheel)
14	736-0119		L-Wash. 5/16" I.D.*	63	**		Shld. Bolt .5 Dia. x 2.62"
15	712-0267		Hex Nut 5/16-18 Thd.*	64	738-0481		FI-Wash. .281" I.D.
16	746-0554		Control Cable—40.5"	65	736-0463		Bell-Wash. .46" I.D.
17	726-0240		Cable Tie	72	736-0453		21" Blade
18	710-0671		Curved Carriage Bolt 5/16-18 x 1.38" Lg.	73	742-0306A		Blade Adapter Kit
				74	753-0485		Hex Bolt 7/16-20 x 1.5" Lg.
19	749-0504C		Lower Handle	75	710-0757		Height Adj. Plate
22	735-0639		Spark Plug Boot (Optional)	76	15261A		Pivot Bar
27	—		Engine	77	15262B		Spring Lever Ass'y. w/Knob
29	734-1661		Wheel Ass'y. Comp.—Steel Rim	78	14832		Shld. Bolt .50" Dia. x .357"
30	734-1653		Wheel Ass'y. Comp.—Plastic Rim	79	738-0507B		Bell-Wash. .38" I.D. x .88" O.D.
				80	736-0105		Height Adj. Ass'y. Comp.—R.H.
31	710-1055		Hex Bolt 3/8-24 x 1"	82	14578		Height Adj. Ass'y.
32	736-0169		L-Wash. 3/8" I.D.		14579		Comp.—L.H. (Not Shown)
33	712-0241		Hex Nut 3/8-24 Thd.	83	**		Front Wheel Ass'y. Comp.
34	731-0858		Seal—Extrusion	84	14764C		Index Plate
35	714-0104		Int. Cotter Pin 5/16" Dia.	85	17488		Pivot Bar—R.H.
36	726-0106		Cap Speed Nut		17489		Pivot Bar—L.H. (Not Shown)
37	747-0698B		Hinge Pin 17.75" Lg.	86	720-0190		Spring Lever Knob
38	750-0566		Spacer .255" I.D.	87	732-0417A		Spring Lever
39	732-0577A		Torsion Spring—L.H.	88	17490		Rear Height Adj. Ass'y.
40	711-0805		Shld. Pin 3/8-24 x 1.43" Lg.				Comp.—R.H.
41	736-0169		L-Wash. 3/8" I.D.*		17491		Rear Height Adj. Ass'y.
42	712-0711		Hex Jam Nut 3/8-24 Thd.				Comp.—L.H. (Not Shown)
43	732-0578A		Torsion Spring—R.H.	89	**		Front Axle Bolt
44	12297A		Handle Brkt. Ass'y.—L.H.	90	736-0232		Wave Wash. .53" I.D. x .78" O.D. (Used w/Ball Brg.)
45	710-1017		Torx Mach. AB-Tap Scr. 1/4 x .62" Lg.	92	720-0224		Grass Catcher Locking Knob
46	731-0970B		Deflector Plug	93	736-0498		Internal L-Wash. 1/4" I.D.
47	731-0931		Corner Plug	94	736-0286		Wave Washer 3/8" I.D.
48	12296A		Handle Brkt. Ass'y.—R.H.	95	738-0137		Shld. Bolt .342" Dia. x .268" Lg.
49	710-0892		Hex L-Wash. AB-Tap Scr. 1/4 x .62" Lg.	96	731-0564		Plug
				99	736-0456		FI-Wash. .51" I.D. x 1.373"
50	736-0356		Bell-Wash. .39" I.D.	100	736-0182		Spr. Wash. .5" I.D. x 1" O.D.
51	712-0798		Hex Nut 3/8-16 Thd.*				

****FRONT WHEEL CHART**

Wheels w/o Bearings			Wheels With Bearings			
Tread***	Ass'y. Comp.	Axle Bolt	Tread***	Ass'y. Comp.	Bearings	Axle Bolt
Diamond	734-1698 (7")	738-0102	"S" Wave	734-1513B (Gray)	Ball Brg. 1/2" I.D.-741-0180 (2 per Wheel)	738-0102
	734-1697 (8")	738-0102		734-1517B (Beige)	Ball Brg. 1/2" I.D.-741-0180 (2 per Wheel)	738-0102
Bar	734-1609 (7")	738-0102	Waffle	734-0645	Ball Brgs. 3/8" I.D.-741-0267, 1/2" I.D.-741-0484, Spacer-750-0434	710-1020
	734-1608 (8")	738-0102				
"S" Wave	734-1512A (8")	738-0102	"T" Tread	734-1259 734-1260	Ball Brgs. 3/8" I.D.-741-0267, 1/2" I.D.-741-0484, Spacer 750-0434 Ball Brg. 1/2" I.D.-741-0180 (2 per Wheel)	710-1020
Waffle	734-1162A (8")	738-0102				
Rib	734-1169 (8")	738-0144				

***Tread Type: Waffle  ; Rib  ; Bar  ; "T" Tread  ; "S" Wave  ; Diamond 

TROUBLE SHOOTING GUIDE

Trouble	Possible Cause(s)	Corrective Action
Engine fails to start	<ol style="list-style-type: none"> 1. Blade control handle disengaged. 2. Spark plug wire disconnected. 3. Throttle control lever not in CHOKE or START position. 4. Fuel shut-off valve closed (if so equipped). 5. Fuel tank empty, or stale fuel. 6. Blocked fuel line. 7. Faulty spark plug. 8. Engine flooded. 	<ol style="list-style-type: none"> 1. Engage blade control handle. 2. Connect wire to spark plug. 3. Move throttle lever to CHOKE or START position. 4. Open fuel shut-off valve. 5. Fill tank with clean, fresh gasoline. 6. Clean fuel line. 7. Clean, adjust gap or replace. 8. Remove spark plug, dry the plug, and crank engine with plug removed and throttle in off position. Replace spark plug, connect wire and resume starting procedures.
Engine runs erratic	<ol style="list-style-type: none"> 1. Unit running in CHOKE or START position. 2. Spark plug wire loose. 3. Blocked fuel line or stale fuel. 4. Vent in gas cap plugged. 5. Water or dirt in fuel system. 6. Dirty air cleaner. 7. Carburetor out of adjustment. 	<ol style="list-style-type: none"> 1. Move throttle lever to FAST position. 2. Connect and tighten spark plug wire. 3. Clean fuel line; fill tank with clean, fresh gasoline. 4. Clear vent. 5. Drain fuel tank. Refill with fresh fuel. 6. Clean air cleaner.† 7. Adjust carburetor.†
Engine overheats	<ol style="list-style-type: none"> 1. Engine oil level low. 2. Air flow restricted. 3. Carburetor not adjusted properly. 	<ol style="list-style-type: none"> 1. Fill crankcase with proper oil. 2. Remove blower housing and clean.† 3. Adjust carburetor.†
Occasional skip (hesitates) at high speed	<ol style="list-style-type: none"> 1. Spark plug gap too close. 2. Carburetor idle mixture adjustment improperly set. 	<ol style="list-style-type: none"> 1. Adjust gap to .030". 2. Adjust carburetor.†
Idles poorly	<ol style="list-style-type: none"> 1. Spark plug fouled, faulty or gap too wide. 2. Carburetor improperly adjusted. 3. Dirty air cleaner. 	<ol style="list-style-type: none"> 1. Reset gap to .030" or replace spark plug. 2. Adjust carburetor.† 3. Clean air cleaner.†
Excessive vibration	<ol style="list-style-type: none"> 1. Cutting blade loose or unbalanced. 2. Bent cutting blade. 	<ol style="list-style-type: none"> 1. Tighten blade and adapter. Balance blade. 2. Replace blade.
Mower will not discharge grass	<ol style="list-style-type: none"> 1. Engine speed too low. 2. Wet grass. 3. Excessively high grass. 	<ol style="list-style-type: none"> 1. Set throttle between 3/4 and full throttle. 2. Do not mow when grass is wet; wait until later to cut. 3. Mow once at a high cutting height, then mow again at desired height or make a narrower cutting swath (1/2 width).
Uneven cut	<ol style="list-style-type: none"> 1. Wheels not positioned correctly. 2. Dull blade. 	<ol style="list-style-type: none"> 1. Place all four wheels in same height position. 2. Sharpen or replace blade.

†Refer to separate engine manual packed with your unit.

Note: For repairs beyond the minor adjustments listed above, contact your local authorized service dealer.